

**Recommended PCB Layout**  
as viewed from component side

▨ Solder Area □ Component Outline

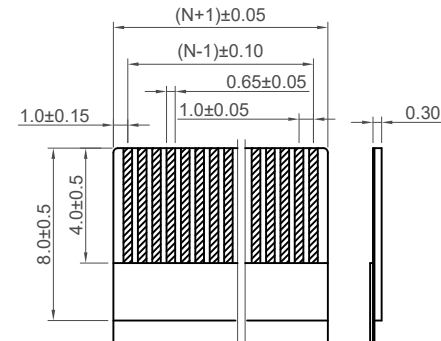

**Recommended FFC/FPC Dimensions**  
Thickness: 0.30±0.03

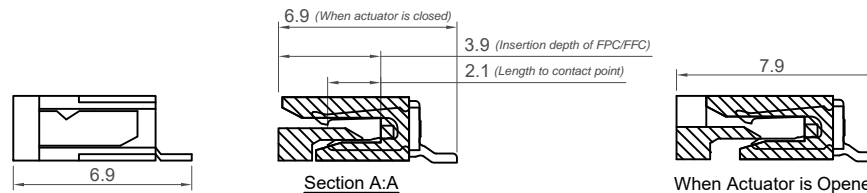

Section A:A

When Actuator is Opened

| No. of Contacts | Dimension |       |       |       |
|-----------------|-----------|-------|-------|-------|
|                 | A         | B     | C     | D     |
| 4               | 9.10      | 3.00  | 11.00 | 5.10  |
| 6               | 11.10     | 5.00  | 13.00 | 7.10  |
| 8               | 13.10     | 7.00  | 15.00 | 9.10  |
| 9               | 14.10     | 8.00  | 16.00 | 10.10 |
| 12              | 17.10     | 11.00 | 19.00 | 13.10 |
| 14              | 19.10     | 13.00 | 21.00 | 15.10 |
| 20              | 25.10     | 19.00 | 27.00 | 21.10 |
| 30              | 35.10     | 29.00 | 37.00 | 31.10 |

**Specification 规格**

**Material 物料**

Housing 塑胶外壳: LCP (UL 94V-0), White  
Actuator: LCP (UL 94V-0), Black  
Contact 接触: Phosphor Bronze  
Fitting Nail: Brass

**Plating 电镀**

Underplating 底层电镀: Nickel-plated all over  
Contact Area 接触部分: see ordering grid  
Fitting Nail: Tin

**Electrical 电气**

Voltage Rating 电压额定值: 50V AC/DC max.  
Current Rating 电流额定值: 0.4A AC/DC max.  
Dielectric Strength 耐电压: 500V AC for 1 minute  
Insulation Resistance 绝缘电阻值: 50 MΩ min. 250V DC  
Contact Resistance 接触电阻值: 40 mΩ max.  
Solder Profile: Peak Temp 260°C (+0/-5°C) max.  
(5 seconds)

**Mechanical & Environmental 机械 & 环境**

Operating Temperature 工作温度: -25°C to +85°C  
Durability 耐久性: 20 Cycles

**Ordering Grid**

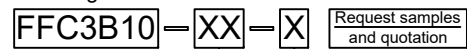

No. of Contacts  
04 - 30 (see dimension table)

Contact Plating  
**T= Tin Plating over all (Standard)**  
reel qty=1500pcs

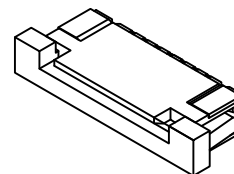

|               |                  |   |             |
|---------------|------------------|---|-------------|
| Part Number   |                  | Product Description                             |             |
| FFC3B10       |                  | FPC 1.0mm Pitch Side Entry                      |             |
| Drawing Date  |                  | Top Contact, SMT, Height=2.5mm, ZIF, Slide Type |             |
| 25th May 2010 |                  |   |             |
| By            | CC               | Tolerances (Except as Noted)                    | Units:      |
| Detail        | FFC3B10<br>B PCN | Length<br>X.X ± 0.30 X.XX ± 0.15 X.XXX ± 0.10   | Metric (mm) |
| Revision      | B                | Angle<br>X.X° ± 2° X.XX° ± 1° X.XXX° ± 0.5°     |             |
| Date          | 21/12/16         |   |             |



This drawing is confidential and copyright of Global Connector Technology, Ltd (GCT). This drawing must not be copied or disclosed without written consent. E & OE





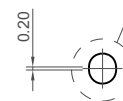
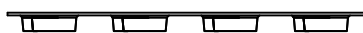
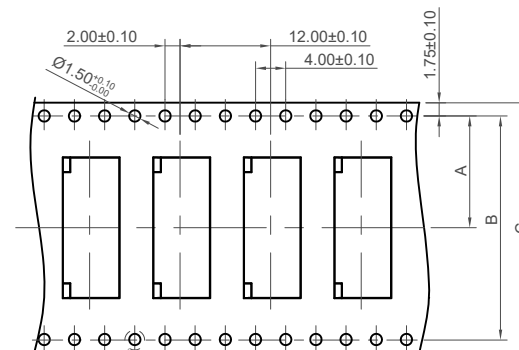
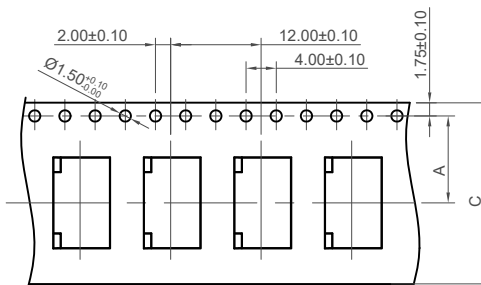
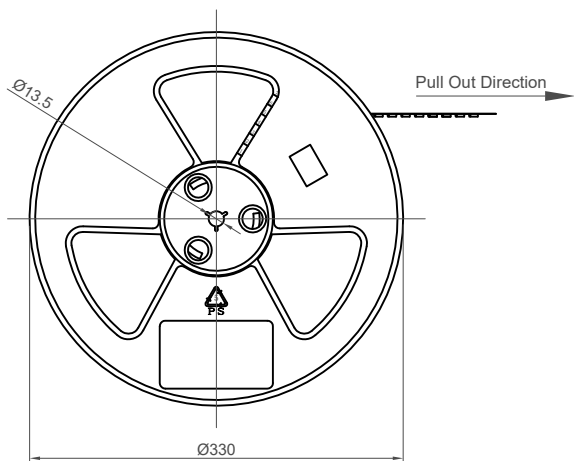
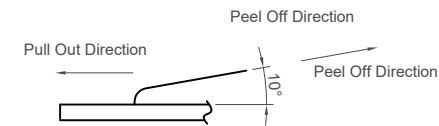
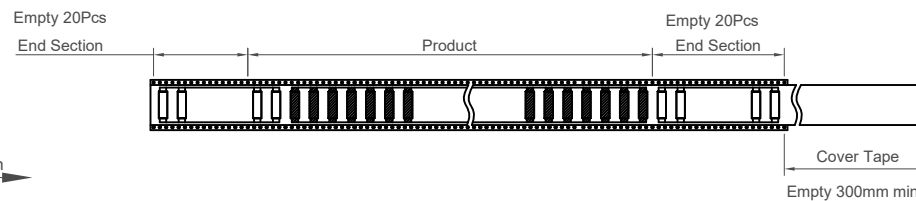
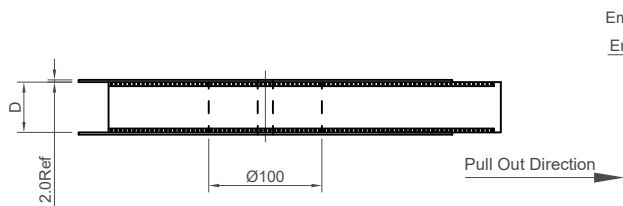

Not to Scale Drawn By FKN Sheet No. 1/2



| No. of Contacts | Dimensions |           |           |           |
|-----------------|------------|-----------|-----------|-----------|
|                 | A          | B         | C         | D         |
| 4 ~ 9           | 11.5±0.10  | /         | 24.0±0.30 | 24.4±0.30 |
| 10 ~ 14         | 14.2±0.10  | 28.4±0.20 | 32.0±0.30 | 32.4±0.30 |
| 15 ~ 27         | 20.2±0.15  | 40.4±0.20 | 44.0±0.30 | 44.4±0.30 |
| 28 ~ 30         | 26.2±0.15  | 52.4±0.20 | 56.0±0.30 | 56.4±0.30 |

**NOTES:**

- Number of Connectors:  
1500 Pcs/Reel
- Material  
Carrier Tape: PET, PE, PEF  
Reel: PS
- Peeling off force of top tape  
10gf~100gf

|              |          |   |             |   |   |              |          |           |  |     |     |
|--------------|----------|---|-------------|---|---|--------------|----------|-----------|--|-----|-----|
| Part Number  |          | Product Description                             |             | <br><a href="http://www.gct.co">www.gct.co</a> |   |              |          |           |  |     |     |
| FFC3B10      |          | FPC 1.0mm Pitch Side Entry                      |             |   |   |              |          |           |  |     |     |
| Drawing Date |          | Top Contact, SMT, Height=2.5mm, ZIF, Slide Type |             |   |   |              |          |           |  |     |     |
| By           |          | CC  |             | 25th May 2010   |   |              |          |           |  |     |     |
| Detail       | Revision | Tolerances (Except as Noted)                    |             | Units:  |    |              |          |           |  |     |     |
|              |          | Length  | Angle       |   |   | Metric (mm)  |          |           |  |     |     |
|              | B        | X.X ± 0.30                                      | X.X° ± 5°   |   |  This drawing is confidential and copyright of Global Connector Technology, Ltd (GCT).<br>This drawing must not be copied or disclosed without written consent. E & OE |              |          |           |  |     |     |
|              | B        | X.XX ± 0.20                                     | X.XX° ± 3°  |   |   |              |          |           |  |     |     |
| Date         | 21/12/16 | X.XXX ± 0.10                                    | X.XXX° ± 1° |    | <table border="1"> <tr> <td>Not to Scale</td> <td>Drawn By</td> <td>Sheet No.</td> </tr> <tr> <td></td> <td>PKN</td> <td>2/2</td> </tr> </table>  | Not to Scale | Drawn By | Sheet No. |  | PKN | 2/2 |
| Not to Scale | Drawn By | Sheet No.                                       |             |   |   |              |          |           |  |     |     |
|              | PKN      | 2/2   |             |   |   |              |          |           |  |     |     |